

# Bright 53



Wi-Fi module



Característica estándar de doble sellado



Envasa al vacío más productos al mismo tiempo



## El máximo de funciones y fiabilidad

Máquinas de envasado al vacío exclusivas con cámara de vacío "Power-Steel", resistencia doble, sistema de inyección de gas, sensor de vacío absoluto y sistema "Easy" para el mejor nivel de vacío externo. Bright 53 garantiza un vacío perfecto y duradero gracias a la alta presión de sellado que garantiza un sellado insuperable.

### Bright 53 es ideal para:



Restaurantes



Hotel



Catering



Carnicerías



Fábrica de quesos



Laboratorios de procesamiento de alimentos

### Programas de envasado



Solo sellado



Vacío



Vacío externo



Vacío ATM

## Programas Chef y Contenedores



Carnes



Pollo



Pescados



Sólidos/  
Rellenos



Salsas



Salsas densas



Marinar



Productos de  
panadería



Vegetales



Polvos y  
Especias



Postre



Bases de  
pastelería



No stop



Tarros  
SENSOR



Tarros  
MIN



Tarros  
MED



Tarros  
MAX



Tarros  
EXTREME

## Datos técnicos

- > Carrocería: acero inoxidable
- > Medidas: 720x720x1015h mm
- > Cámara de vacío: 575x575x160h mm
- > Barra de soldadura: 1x 530 mm  
2x 530 mm (opcional)
- > Tamaño máx de bolsa: 500x500 mm
- > Distancia entre ejes de barras: 481 mm

### Bomba de vacío 25 mc/h

- > Peso: 125 kg
- > Tensión: 220-240V 50/60Hz
- > Potencia máx: 1500 W

### Bomba de vacío 60 mc/h

- > Peso: 145 kg
- > Tensión: 400V 50/60Hz 3ph +PE
- > Potencia máx: 2300 W

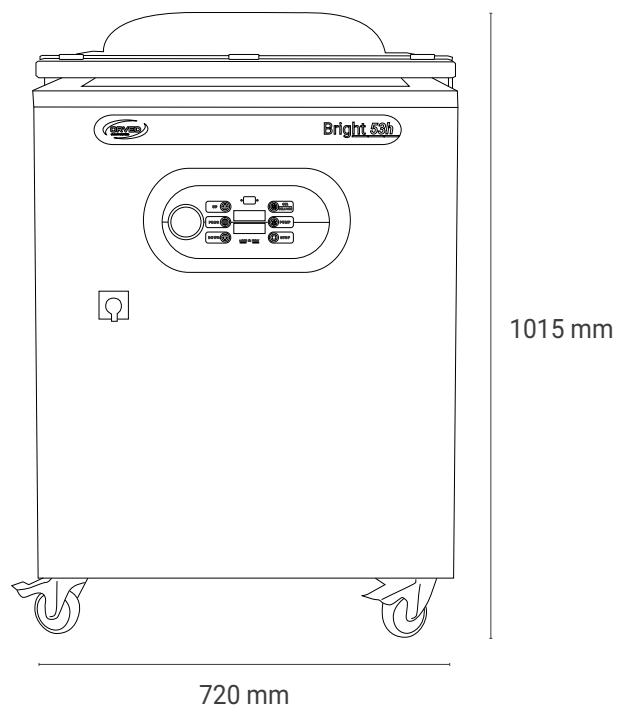

## Equipamiento estandar

- Mandos digitales, 48 programas
- Sistema de vacío con sensor absoluto
- Doble soldadura
- Vacío Gas (ATM)
- H2out programa de deshumidificación de bomba
- Puerto USB para actualización del firmware
- Contrabarra desmontable

## Opcional disponibles

- Recorte sobrante de bolsa
- Easy, para la creación del vacío externo
- Softair
- Kit bolsas Premium
- Boquilla para contenedores externos
- Módulo de Wi-Fi
- Bomba Extra

## Accesorios



Bolsas de Vacío Lisas



Bolsas de Vacío Gofradas



Bolsas de Cocción al Vacío



Conserbox



Easy, para la creación del vacío externo



Estantes Planos Inclinados